

CERAMIC INSERTS

Pages 134-137

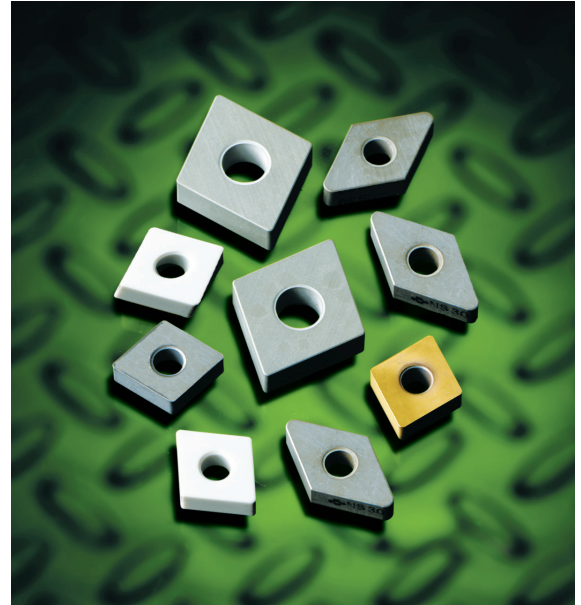

Ceramic
Inserts

CERAMIC INSERTS

PAGES

Ceramic Inserts 134-137

CERAMIC INSERTS - NEGATIVE

Advanced Cutting Materials

- SN2000K*** → Finishing and roughing of cast iron
- SN2100K*** → Interrupted turning /milling of cast iron
- SN1000S** → SiAlON grade for continuous turning of exotic alloys
- SN2000S** → SiAlON grade for continuous to medium interrupted turning of exotic alloys

- WX1500** → Cold pressed whiskered ceramic grade for continuous turning of exotic alloys
- WX2500** → High speed turning of super alloys
- WX2000** → High speed turning of super alloys
- NB150H** → High speed finishing of hardened steels
- NB90S** → High speed finishing of hardened steels

*SN2000K & SN2100K grades not shown in stock can be made to order. Call for price and delivery.

■ NEGATIVE

● USA Stocked Item ★ Worldwide Warehouse Item ▲ USA Limited Availability Item ○ In stock by 1st Quarter 2017

Ceramic Inserts

Cutting Conditions:					SN2000K
Continuous Cut					
Medium Cut					
Interrupted Cut					SN2000K
CNMA					
Catalog #	I.C.	T	r	Hole Dia.	
CNMA432	.500	.1875	.0313	.2031	
CNMA433			.0469		
CNMA434			.0625		
CNMA454			.3125		.0625
CNMA543	.625	.250	.0469	.250	
CNMA544			.0625		

Cutting Conditions:					SN2000K
Continuous Cut					
Medium Cut					
Interrupted Cut					SN2000K
CNMN					
Catalog #	I.C.	T	r	Hole Dia.	
CNMN434	.500	.1875	.0625	-	

Cutting Conditions:					SN2000K
Continuous Cut					
Medium Cut					
Interrupted Cut					SN2000K
CNGX					
Catalog #	I.C.	T	r	Hole Dia.	
CNGX452	.500	.3125	.0313	-	

Cutting Conditions:					SN2000K
Continuous Cut					
Medium Cut					
Interrupted Cut					SN2000K
CNMX					
Sumitomo Catalog #	I.C.	T	r	Hole Dia.	
CNMX453	.500	.3125	.0469	-	
CNMX454	.500	.3125	.0625	-	

Cutting Conditions:					Grades		
Continuous Cut					SN2000K	WX2000	NB90S
Medium Cut					SN2000K	WX2000	NB90S
Interrupted Cut					SN2000K	WX2000	NB90S
CNG							
Catalog #	I.C.	T	r	Hole Dia.	SN2000K	WX2000	NB90S
CNG432	.500	.1875	.0313	-	●	●	●
CNG433			.0469		●	●	●
CNG434			.0625		●	●	●
CNG452			.0313		●	●	●
CNG453	.3125	.0469	.0469	-	●	●	●
CNG454			.0625		●	●	●
CNG643			.750		.250	.0469	●

K Cast Iron
S Exotic Materials
H Hardened Steel

Cutting Conditions:					Grades											
Continuous Cut					SN2000K	SN2100K	SN1000S	SN2000S	WX1500	WX2500	WX2000	NB150H	NB90S			
Medium Cut					SN2000K	SN2100K	SN1000S	SN2000S	WX1500	WX2500	WX2000	NB150H	NB90S			
Interrupted Cut					SN2000K	SN2100K	SN1000S	SN2000S	WX1500	WX2500	WX2000	NB150H	NB90S			
CNGA																
Catalog #	I.C.	T	r	Hole Dia.	SN2000K	SN2100K	SN1000S	SN2000S	WX1500	WX2500	WX2000	NB150H	NB90S			
CNGA431	.500	.1875	.0156	.2031	●	●	○	○	○	○	○	○	▲			
CNGA432			.0313		●	●	○	○	○	○	○	○	○	○	▲	
CNGA433			.0469		●	●	○	○	○	○	○	○	○	○	○	▲
CNGA434			.0625		●	●	○	○	○	○	○	○	○	○	○	▲
CNGA542	.625	.250	.0313	.250	●	●	○	○	○	○	○	○	○	▲		
CNGA543			.0469		●	●	○	○	○	○	○	○	○	○	▲	
CNGA544			.0625		●	●	○	○	○	○	○	○	○	○	○	▲
CNGA643			.750		.250	.0469	.3126	●	●	○	○	○	○	○	○	○
CNGA644	.750	.250	.0625	.3126	●	●	○	○	○	○	○	○	○			

Cutting Conditions:					Grades							
Continuous Cut					SN2000K	SN1000S	SN2000S	WX2500	WX2000	NB150H	NB90S	
Medium Cut					SN2000K	SN1000S	SN2000S	WX2500	WX2000	NB150H	NB90S	
Interrupted Cut					SN2000K	SN1000S	SN2000S	WX2500	WX2000	NB150H	NB90S	
DNGA												
Catalog #	I.C.	T	r	Hole Dia.	SN2000K	SN1000S	SN2000S	WX2500	WX2000	NB150H	NB90S	
DNGA432	.500	.1875	.0313	.2031	●	○	○	○	○	○	○	
DNGA433			.0469		●	○	○	○	○	○	○	○
DNGA434			.0625		●	○	○	○	○	○	○	○



CERAMIC INSERTS - NEGATIVE

- SN2000K*** → Finishing and roughing of cast iron
- SN2100K*** → Interrupted turning /milling of cast iron
- SN1000S** → SiAlON grade for continuous turning of exotic alloys
- SN2000S** → SiAlON grade for continuous to medium interrupted turning of exotic alloys

*SN2000K & SN2100K grades not shown in stock can be made to order. Call for price and delivery.



- WX1500** → Cold pressed whiskered ceramic grade for continuous turning of exotic alloys
- WX2500** → High speed turning of super alloys
- WX2000** → High speed turning of super alloys
- NB150H** → High speed finishing of hardened steels
- NB90S** → High speed finishing of hardened steels

K Cast Iron
S Exotic Materials
H Hardened Steel

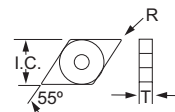
- USA Stocked Item
- ★ Worldwide Warehouse Item
- ▲ USA Limited Availability Item
- In stock by 1st Quarter 2017

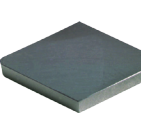
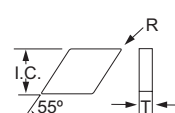
Cutting Conditions:					
DNMX					
Continuous Cut					
Medium Cut					
Interrupted Cut					
					SN2000K
Catalog #	I.C.	T	r	Hole Dia.	
DNMX354	.375	.3125	.0625	.2031	
DNMX454	.500		.0625		

Cutting Conditions:					
DNG					
Continuous Cut					
Medium Cut					
Interrupted Cut					
					SN2000K
Catalog #	I.C.	T	r	Hole Dia.	
DNG432			.0313		
DNG433	.500	.1875	.0469	.2031	
DNG434			.0625		

Cutting Conditions:						Grades								
RNG						SN2000K	SN2100K	SN1000S	SN2000S	WX1500	WX2500	WX2000	NB150H	NB90S
Continuous Cut						●	●	○	○	○	○	○	○	○
Medium Cut						●	●	○	○	○	○	○	○	○
Interrupted Cut						●	●	○	○	○	○	○	○	○
					SN2000K	SN2100K	SN1000S	SN2000S	WX1500	WX2500	WX2000	NB150H	NB90S	
Catalog #	I.C.	T	r	Hole Dia.										
RNG32	.375	.125												
RNG33		.1875												
RNG42		.125												
RNG43	.500	.1875	-	-										
RNG45														
RNG55	.625	.3125												
RNG65	.750													
RNG86	1.00	.375	-	-										

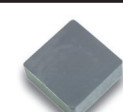
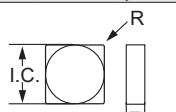
Cutting Conditions:					
SNMN					
Continuous Cut					
Medium Cut					
Interrupted Cut					
					SN2000K
Catalog #	I.C.	T	r	Hole Dia.	
SNMN434	.500	.1875	.0625	.2031	

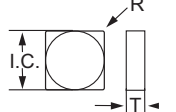
Cutting Conditions:					
SNMX					
Continuous Cut					
Medium Cut					
Interrupted Cut					
					SN2000K
Catalog #	I.C.	T	r	Hole Dia.	
SNMX453	.500		.0469		
SNMX454	.500	.3125	.0625	-	
SNMX554	.625		.0625		

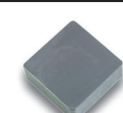
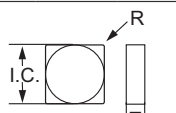
Cutting Conditions:						Grades		
SNG						SN2000K	SN2100K	WX2000
Continuous Cut						●	●	●
Medium Cut						●	●	●
Interrupted Cut						●	●	●
					SN2000K	SN2100K	WX2000	
Catalog #	I.C.	T	r	Hole Dia.				
SNG432			.0313					
SNG433	.500	.1875	.0469	-				
SNG434			.0625					

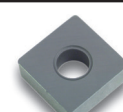
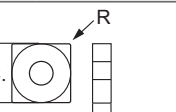
Cutting Conditions:						Grades		
SNGA						SN2000K	WX2000	NB90S
Continuous Cut						●	●	●
Medium Cut						●	●	●
Interrupted Cut						●	●	●
					SN2000K	WX2000	NB90S	
Catalog #	I.C.	T	r	Hole Dia.				
SNGA432			.0313					
SNGA433	.500	.1875	.0469	.2031				
SNGA434			.0625					



CERAMIC INSERTS - NEGATIVE

Advanced Cutting Materials

Ceramic Inserts

- SN2000K*** → Finishing and roughing of cast iron
- SN2100K*** → Interrupted turning /milling of cast iron
- SN1000S** → SiAlON grade for continuous turning of exotic alloys
- SN2000S** → SiAlON grade for continuous to medium interrupted turning of exotic alloys
- WX1500** → Cold pressed whiskered ceramic grade for continuous turning of exotic alloys
- WX2500** → High speed turning of super alloys
- WX2000** → High speed turning of super alloys
- NB150H** → High speed finishing of hardened steels
- NB90S** → High speed finishing of hardened steels

*SN2000K & SN2100K grades not shown in stock can be made to order. Call for price and delivery.

- K** Cast Iron
- S** Exotic Materials
- H** Hardened Steel

- USA Stocked Item
- ★ Worldwide Warehouse Item
- ▲ USA Limited Availability Item
- In stock by 1st Quarter 2017

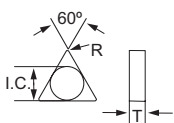
TNG	Cutting Conditions:				Grades	
	Continuous Cut				●	○
	Medium Cut				●	○
	Interrupted Cut				●	○
					SN2000K	NB90S
Catalog #	I.C.	T	r	Hole Dia.	SN2000K	NB90S
TNG321	.375	.125	.0156	.150	●	○
TNG322			.0313		●	○
TNG331			.0156		●	○
TNG332	.1875	.3125	.0313	.2031	●	○
TNG333			.0469		●	○
TNG334			.0625		●	○
TNG352	.500	.3125	.0313	.250	●	○
TNG353			.0469		●	○
TNG432			.0313		●	○
TNG433	.500	.3125	.0469	.250	●	○
TNG434			.0625		●	○
TNG436			.0938		●	○

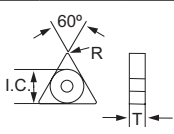
TNGA	Cutting Conditions:				Grades	
	Continuous Cut				●	○
	Medium Cut				●	○
	Interrupted Cut				●	○
					SN2000K	NB90S
Catalog #	I.C.	T	r	Hole Dia.	SN2000K	NB90S
TNGA321	.375	.125	.0156	.150	●	○
TNGA322			.0313		●	○
TNGA332			.0313		●	○
TNGA333	.1875	.3125	.0469	.2031	●	○
TNGA334			.0625		●	○
TNGA432			.0313		●	○
TNGA433	.500	.3125	.0469	.250	●	○
TNGA434			.0625		●	○
TNGA436			.0938		●	○
TNGA438	.625	.250	.1250	.250	●	○
TNGA543			.0469		●	○
TNGA544			.0625		●	○

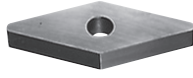
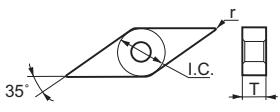
VNGA	Cutting Conditions:				Grades		
	Continuous Cut				●	○	○
	Medium Cut				●	○	○
	Interrupted Cut				●	○	○
					SN2000K	WX2000	NB90S
Catalog #	I.C.	T	r	Hole Dia.	SN2000K	WX2000	NB90S
VNGA331	.375	.1875	.0156	.150	●	○	○
VNGA332			.0313		●	○	○
VNGA333			.0469		●	○	○
VNGA432	.500	.3125	.0313	.2031	●	○	○
VNGA433			.0469		●	○	○

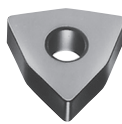
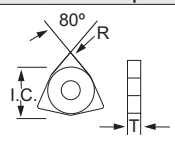
WNGA	Cutting Conditions:				Grades						
	Continuous Cut				●	○	○	○	○	○	○
	Medium Cut				●	○	○	○	○	○	○
	Interrupted Cut				●	○	○	○	○	○	○
					SN2000K	SN2100K	SN1000S	SN2000S	WX2000	NB150H	
Catalog #	I.C.	T	r	Hole Dia.	SN2000K	SN2100K	SN1000S	SN2000S	WX2000	NB150H	
WNGA432	.500	.1875	.0313	.2031	●	○	○	○	○	○	
WNGA433			.0469		●	○	○	○	○	○	
WNGA434			.0625		●	○	○	○	○	○	

POSITIVE

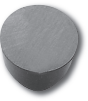
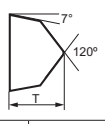
RCGX	Cutting Conditions:				Grades								
	Continuous Cut				●	○	○	○	○	○	○	○	
	Medium Cut				●	○	○	○	○	○	○	○	
	Interrupted Cut				●	○	○	○	○	○	○	○	
					SN2000K	SN1000S	SN2000S	WX1500	WX2500	WX2000	NB150H	NB90S	
Catalog #	I.C.	T	r	Hole Dia.	SN2000K	SN1000S	SN2000S	WX1500	WX2500	WX2000	NB150H	NB90S	
RCGX35	.375	.3125	-	-	●	○	○	○	○	○	○	○	
RCGX45	.500				●	○	○	○	○	○	○	○	○
RCGX55	.625				○	○	○	○	○	○	○	○	○

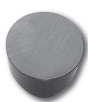
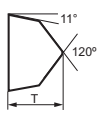
RPGX	Cutting Conditions:				Grades					
	Continuous Cut				●	○	○	○	○	○
	Medium Cut				●	○	○	○	○	○
	Interrupted Cut				●	○	○	○	○	○
					SN1000S	SN2000S	WX1500	WX2500	WX2000	
Catalog #	I.C.	T	r	Hole Dia.	SN1000S	SN2000S	WX1500	WX2500	WX2000	
RPGX35	.375	.3125	-	-	○	○	○	○	○	
RPGX45	.500				○	○	○	○	○	○
RPGX55	.625				○	○	○	○	○	○



SN2000K* → Finishing and roughing of cast iron

SN2100K* → Interrupted turning /milling of cast iron

SN1000S → SiAlON grade for continuous turning of exotic alloys

SN2000S → SiAlON grade for continuous to medium interrupted turning of exotic alloys

*SN2000K & SN2100K grades not shown in stock can be made to order. Call for price and delivery.

- USA Stocked Item
- ★ Worldwide Warehouse Item
- ▲ USA Limited Availability Item
- In stock by 1st Quarter 2017

WX1500 → Cold pressed whiskered ceramic grade for continuous turning of exotic alloys

WX2500 → High speed turning of super alloys

WX2000 → High speed turning of super alloys

NB150H → High speed finishing of hardened steels

NB90S → High speed finishing of hardened steels

- K** Cast Iron
- S** Exotic Materials
- H** Hardened Steel

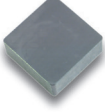
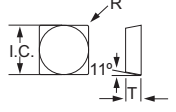
SPG	Cutting Conditions:				Grades		
	Continuous Cut				●	●	●
	Medium Cut				●	●	●
	Interrupted Cut				●	●	●
					SN2000K	SN2100K	NB90S
Catalog #	I.C.	T	r	Hole Dia.			
SPG422	.500	.125	.0313		●	●	●
SPG423			.0469		●	●	●
SPG424			.0625		●	●	●
SPG432			.0313		●	●	●
SPG433	.750	.1875	.0469		●	●	●
SPG632			.0313		●	●	●
SPG633			.0469		●	●	●
SPG634			.0625		●	●	●

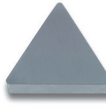
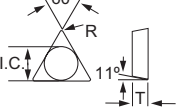
TPG	Cutting Conditions:				Grades		
	Continuous Cut				●	●	●
	Medium Cut				●	●	●
	Interrupted Cut				●	●	●
					SN2000K	SN2100K	NB90S
Catalog #	I.C.	T	r	Hole Dia.			
TPG221	.250	.125	.0156		●	●	●
TPG222			.0313		●	●	●
TPG321	.375	.125	.0156		●	●	●
TPG322			.0313		●	●	●
TPG323			.0469		●	●	●
TPG332			.0313		●	●	●
TPG432	.500	.1875	.0313		●	●	●
TPG433			.0469		●	●	●

For GROOVING

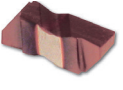
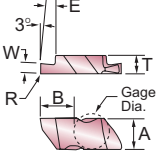
SG	Cutting Conditions:							Grades			
	Continuous Cut							●	●	●	●
	Medium Cut							●	●	●	●
	Interrupted Cut							●	●	●	●
								SN2000K	SN2100K	WX2000	NB90S
Catalog #	W ±.001	R	E ±.001	T	A	B	Gage Dia.				
SG-3047R	.047	.005/.010	.075	.195	.344	.4050	.3750	●	●	●	●
SG-3062R	.062	.005/.010	.094					●	●	●	●
SG-3094R	.094	.005/.010	.150					●	●	●	●
SG-3125R	.125	.005/.010	.150					●	●	●	●

For MILLING

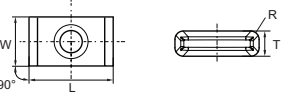
LNGX	Cutting Conditions:				Grades			
	Continuous Cut				●	●	●	●
	Medium Cut				●	●	●	●
	Interrupted Cut				●	●	●	●
					SN2000K	SN2100K	WX2000	NB90S
Catalog #	L	W	T	R				
LNGX160516PNFN-W	.625	.375	.187	.063	●	●	●	●

